

NO. E1FB-3617

ISSUED: OCT.2011

REVISED: FEB.2012



## **HOSHIZAKI MODULAR CUBER**

**MODEL   IM-45NE  
          IM-45NE-25  
          IM-45WNE  
          IM-45WNE-25**

## **PARTS LIST**

[HE, GRAM]

A-1 NOV. 2011  
B-0 JAN. 2012

## AUXILIARY CODE

U - 1

The auxiliary code is the first two characters in the serial number. The first character indicates the production year. Years progress or regress in alphabetical order. The series of letters and skipped letters depend on UL listing, production, and model. See the auxiliary code(s) and corresponding year(s) on the front cover.

The second character indicates significant part changes within the same year. Base is "1" and this number advances for each change. If there is no significant part change at the turn of the year, this number starts from "0."

## MARKS LOCATED UNDER THE AUXILIARY CODE

- = Part deleted.
- x = Part deleted and replaced by "o" part.
- o = New part in place of "x" part.

## FASTENER PART NUMBER

### SCREWS

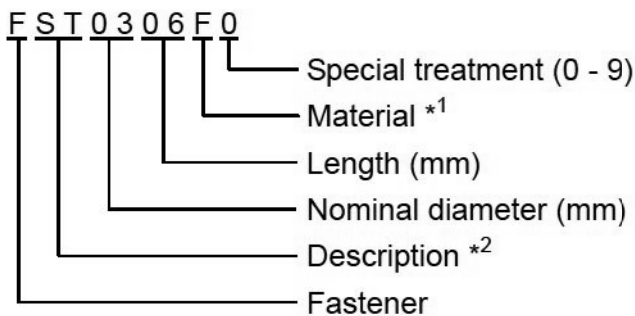

\*1 Material

- F: Steel
- S: Austenitic stainless steel
- M: Martensitic stainless steel
- B: Copper alloy
- P: Polycarbonate
- N: Polyamide
- V: PVC
- A: ABS
- X: Polyacetal
- L: Aluminum

### NUTS & WASHERS

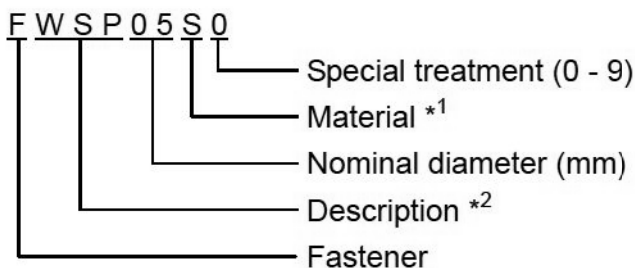

\*2 Description

- First letter
- S: Machine screw
- T: Tapping screw
- M: Wood screw
- B: Bolt
- W: Washer
- N: Nut

IM-45NE  
 IM-45NE-25  
 IM-45WNE  
 IM-45WNE-25

A. ICE CUBER ASSY (1/2)

(A-1) and later

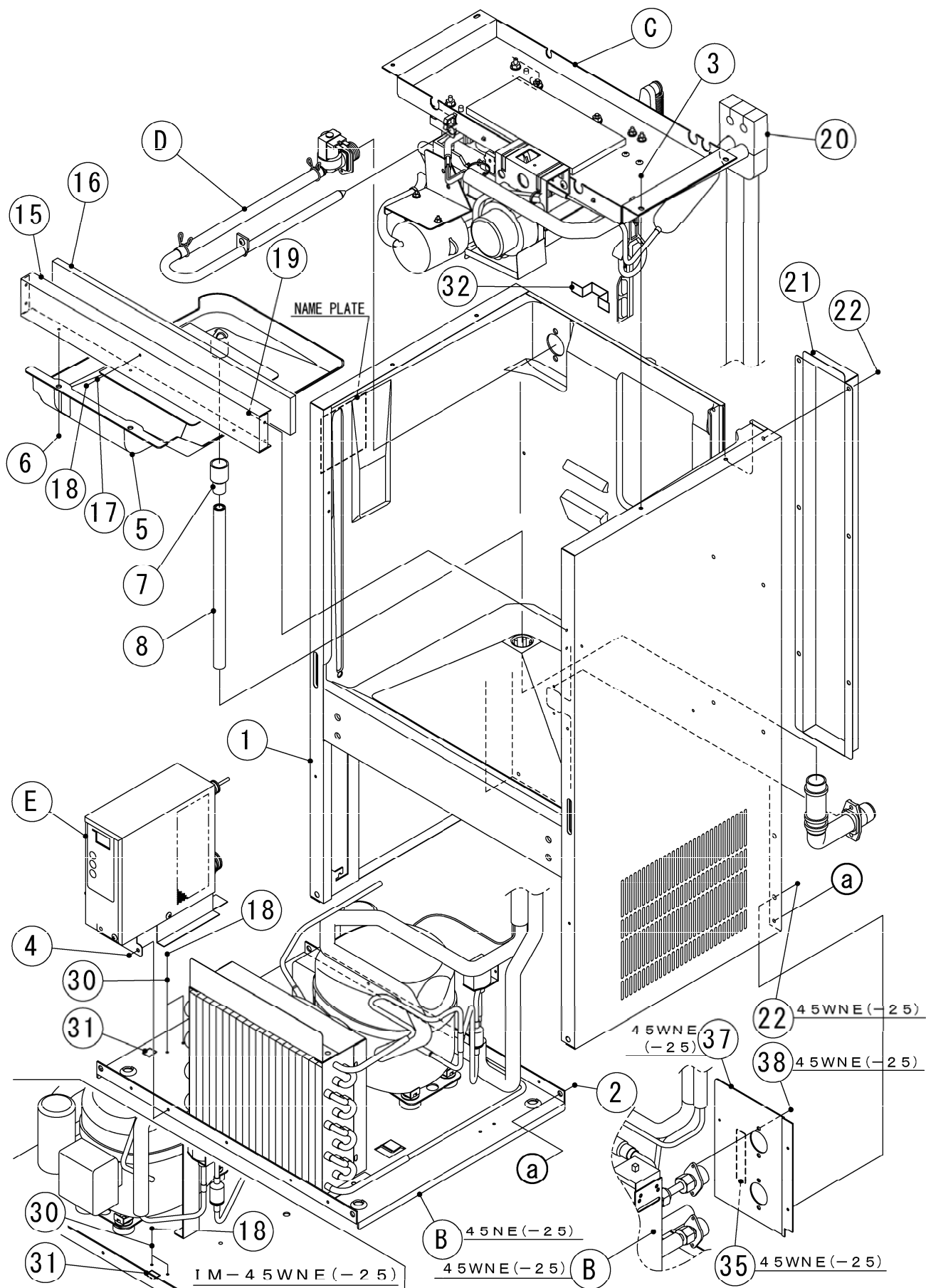

IM-45NE  
 IM-45NE-25  
 IM-45WNE  
 IM-45WNE-25

A. ICE CUBER ASSY (2/2)

(A-1) and later

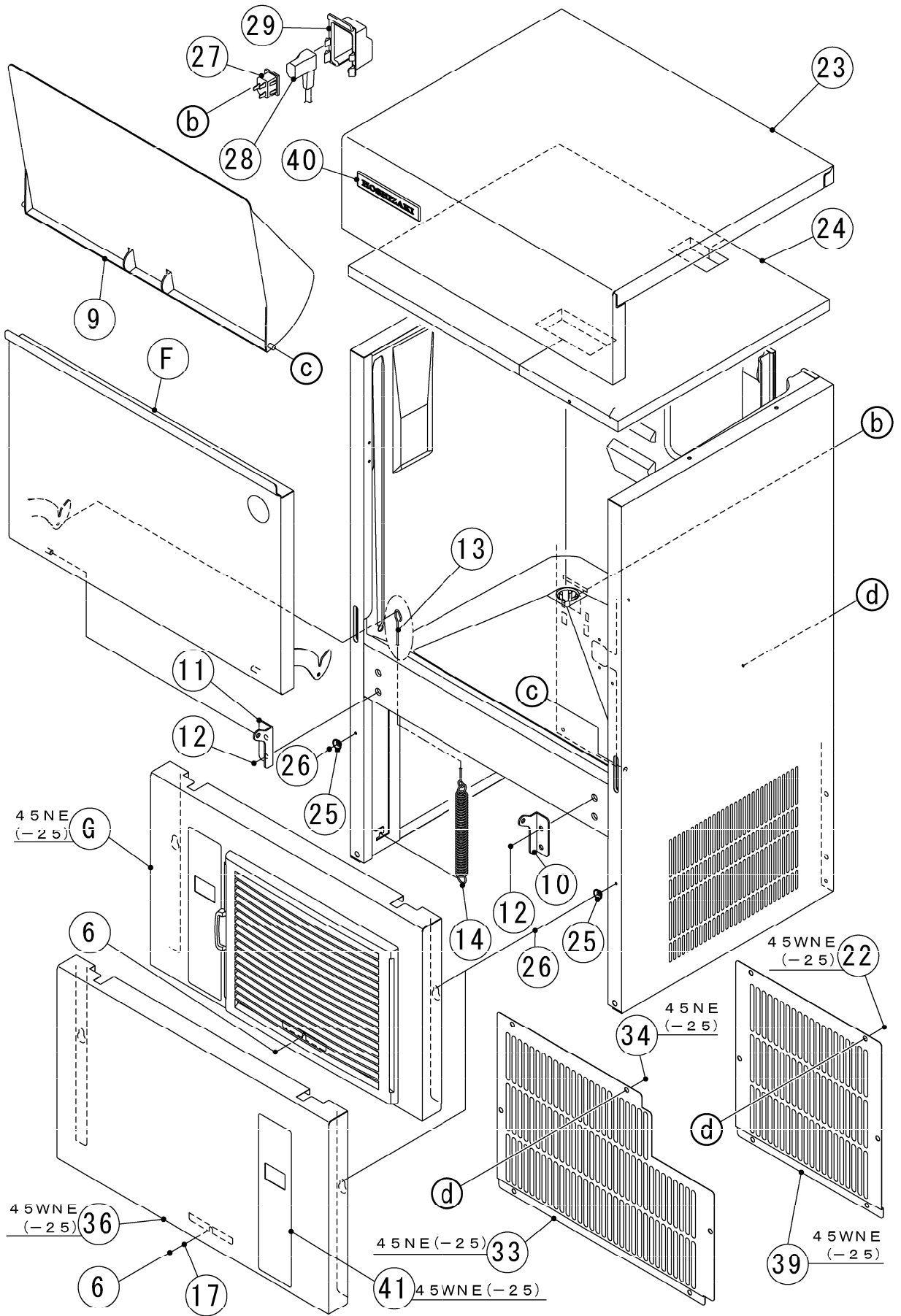

HE,GRAM

MODEL: <b>IM-45NE,IM-45NE-25</b> <b>IM-45WNE,IM-45WNE-25</b>		TITLE: <b>A.ICE CUBER ASSY</b>					
INDEX NO.	DESCRIPTION	MATERIAL OR MODEL NUMBER	PART NUMBER	REQ'D NUMBER			
				A-1 B-0			
B	REFRIGERATION ASSY	(IM-45NE,-25)	1H4815A01	1			
		(IM-45WNE,-25)	1H4914A01	1			
C	ICE MAKING MECHANISM ASSY		1H4816A01	1			
D	WATER CIRCUIT ASSY	(IM-45NE,-25)	3Y5610A01	1			
		(IM-45WNE,-25)	3Y5610A02	1			
E	CONTROL BOX ASSY		2X0439A01	1			
F	DOOR ASSY		3Y5614A01	1			
G	FRONT PANEL LOWER ASSY	(IM-45NE,-25)	3Y5615A01	1			
1	UNIT FRAME		1H4814G01	1			
2	TRUSS HEAD TAPPING SCREW T2	(IM-45NE,-25)	1H4195Z02	4			
	HEX.TAPPING SCREW W/FLANG	(IM-45WNE,-25)	1H4915Z01	4			
3	TRUSS HEAD TAPPING SCREW T2		FT20410S0	4			
4	FLANGE BOLT (S-TITE)		FTR0408M0	2			
5	DRAIN PAN		2H1440-01	1			
6	TRUSS HEAD TAPPING SCREW (S-TITE)		FTS0408M0	3			
7	DRAIN TUBE		4H2585-01	1			
8	DREIN PIPE		4Y7493P03	1			
9	SLOPE		2H1349-01	1			
10	HINGE (RIGHT)		4H2583-01	1			
11	HINGE (LEFT)		4H2584-01	1			
12	HEX HEAD BOLT (SPRING WASHER AND FLAT WASHER)		FBK0616S0	4			
13	HOOK		404060-10	1			
14	SPRING DOOR		416609-01	1			
15	FRONT FRAME		3H1678-11	1			
16	INSULATION - FRONT FRAME		4H2317-02	1			
17	SPRING WASHER		FWSP04S0	2			
18	TRUSS HEAD MACHINE SCREW		FST0408S0	3			
19	RIVET	SSD42SSBS(t1.6~3.2)	7170-0002	4			
20	INSULATION - BIN		4Y7416P01	1			
21	COVER - PIPE		3Y5869M01	1			
22	TRUSS HEAD TAPPING SCREW T2	(IM-45NE,-25)	FT20408F0	6			
		(IM-45WNE,-25)		14			

HE,GRAM

MODEL: <b>IM-45NE,IM-45NE-25</b> <b>IM-45WNE,IM-45WNE-25</b>				TITLE: <b>A.ICE CUBER ASSY</b>			
INDEX NO.	DESCRIPTION	MATERIAL OR MODEL NUMBER	PART NUMBER	REQ'D NUMBER			
				A-1 B-0			
23	FRONT PANEL(UPPER)	(HE) Including No. 40	3Y5548G02	1			
		(GRAM)	3Y5548002	1			
24	INSULATION - TOP		3Y5959P01	1			
25	TAPER COLLAR		4H0171-01	2			
26	RIVET	SSD42BS	7170-0001	2			
27	CONNECTOR		P00245-02	1			
28	POWER CORD	CONT Plug	P00240-01	1			
29	COVER - CONNECTOR	ACCESSORIES NO.5	2X0271P01	1			
30	TOOTH WASHER		FWTB04S0	2			
31	LABEL - GROUND		450452-02	1			
32	CAUTION - LABEL		452552-01	1			
33	REAR LOUVER	(IM-45NE,-25)	3Y5616M01	1			
34	TRUSS HEAD TAPPING SCREW T2	(IM-45NE,-25)	FT20408M0	6			
35	LABEL - CONNECTION	(IM-45WNE,-25)	464541-02	1			
36	FRONT PANEL LOWER(G)	(IM-45WNE,-25) Including No. 41	3Y5939G01	1			
37	BRACKET - WATER	(IM-45WNE,-25)	4Y7399M01	1			
38	TRUSS HEAD TAPPING SCREW (S-TITE)	(IM-45WNE,-25)	FTS0408F0	4			
39	REAR COVER	(IM-45WNE,-25)	3Y5940M01	1			
40	EMBLEM	(HE)	340842-01	1			
	EMBLEM-GRAM	(GRAM)	4Y6123L01	1			
41	OPERATION LABEL	(IM-45WNE,-25)	375116L03	1			

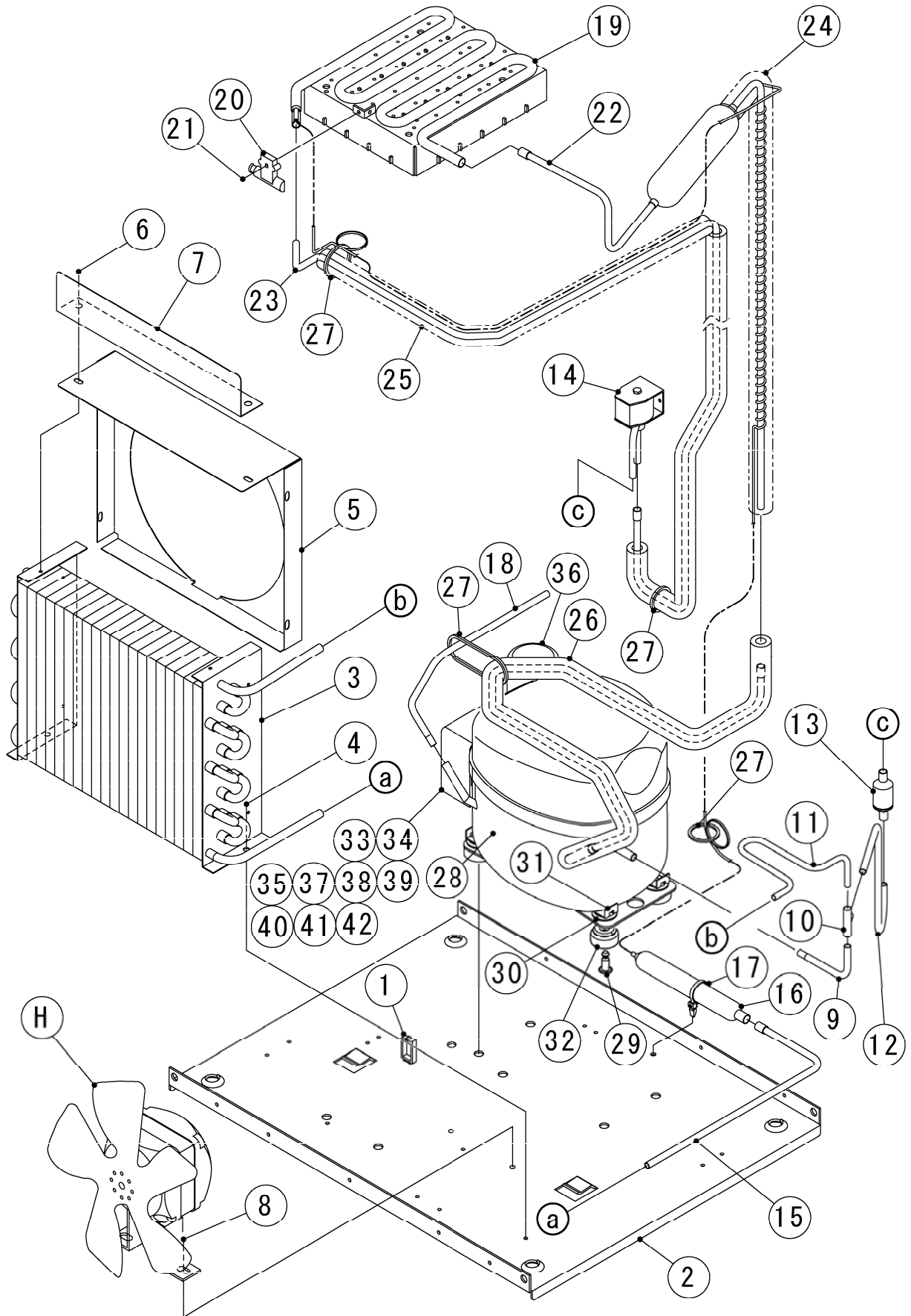

HE,GRAM

MODEL: <b>IM-45NE,IM-45NE-25</b>				TITLE: <b>B.REFRIGERATION ASSY</b>			
INDEX NO.	DESCRIPTION	MATERIAL OR MODEL NUMBER	PART NUMBER	REQ'D NUMBER			
				A-1 B-0			
H	FAN MOTOR ASSY		3Y5605A01	1			
1	WIRE SADDLE		428060-02	1			
2	BASE		2X0433M01	1			
3	CONDENCER		P02262-01	1			
4	FLANGE BOLT (S-TITE)		FTR0408M0	2			
5	SHROUD		3Y5606M01	1			
6	TRUSS HEAD TAPPING SCREW T2		FT20408F0	6			
7	PLATE - CONDENCER		4Y7159M01	1			
8	HEX HEAD BOLT (SPRING WASHER AND FLAT WASHER)		FBK0612F0	2			
9	PIPE(A) - HIGH SIDE		4Y7160M01	1			
10	TEE		417394-01	1			
11	PIPE(B) - HIGH SIDE		4Y7161M01	1			
12	PIPE(A) - HOT		4Y7162M01	1			
13	STRAINER		P00008-01	1			
14	HOT GAS VALVE		P02539-01	1			
15	PIPE(C) - HIGH SIDE		4Y7163M01	1			
16	DRIER		P00007-01	1			
17	PUSH MOUNT TIE		436156-01	1			
18	PROSESS PIPE		4Y7164M01	1			
19	EVAPORATOR	(IM-45NE)	3H5611G02	1			
		(IM-45NE-25)	3H3941G01	1			
20	HOLDER - THERMISTOR		3H9642-01	1			
21	TRUSS HEAD TAPPING SCREW (S-TITE)		FTS0408M0	1			
22	HEAT EXCHANGER		4Y7168G01	1			
23	PIPE(B) - HOT		3Y5608G01	1			
24	Insulation Tube (Food Sanitation Law)		H81323550	1			
25	INSULATION TUBE		H81020550	1			
26	PIPE(A) - LOW SIDE		3Y5607G01	1			
27	NYLON TIE	CV-100	7920-0002	4			
28	COMPRESSOR	(50Hz)	P02286-01	1			
		(60Hz)	P02617-01	1			
29	PIN		P02605-01	4			
30	WASHER		P02606-01	4			
31	CLAMP		P02607-01	4			



HE,GRAM

MODEL: <b>IM-45NE,IM-45NE-25</b>				TITLE: <b>B.REFRIGERATION ASSY</b>			
INDEX NO.	DESCRIPTION	MATERIAL OR MODEL NUMBER	PART NUMBER	REQ'D NUMBER			
				A-1 B-0			
32	RUBBER GROMMET		P02608-01	4			
33	TERMINAL COVER		P02609-01	1			
34	SCREW		P00840-01	2			
35	BRACKET FOR CAPACITOR		P02610-01	1			
36	START CAPACITOR	(50Hz)	P02620-01	1			
		(60Hz)	P02611-01	1			
37	TERMINAL BOARD		P02612-01	1			
38	STARTING RELAY	(50Hz)	P02613-01	1			
		(60Hz)	P02619-01	1			
39	MOTER PROTECTOR	(50Hz)	P02618-01	1			
		(60Hz)	P02614-01	1			
40	PROTECTOR RETAINER		P00839-01	1			
41	SELF TAPPING SCREW M4-11		P02615-01	1			
42	SELF TAPPING SCR W M4-21		P02616-01	1			

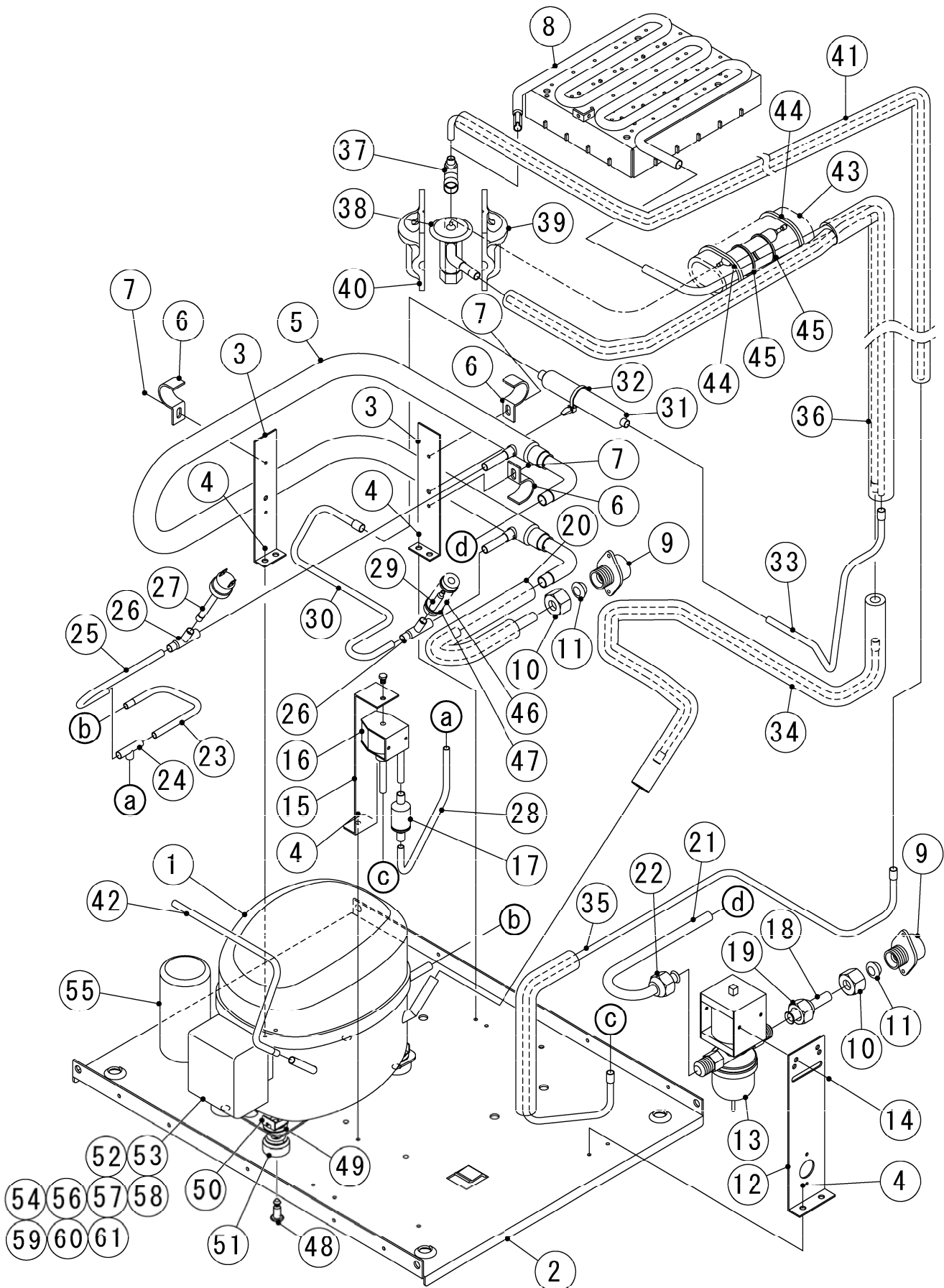

HE

MODEL: <b>IM-45WNE,IM-45WNE-25</b>		TITLE: <b>B.REFRIGERATION ASSY</b>					
INDEX NO.	DESCRIPTION	MATERIAL OR MODEL NUMBER	PART NUMBER	REQ'D NUMBER			
				A-1 B-0			
1	COMPRESSOR	(50Hz)	P02286-01	1			
	COMPRESSOR	(60Hz)	P02617-01	1			
2	BASE		2X0433M01	1			
3	BRACKET - CONDENSER		4H5731-01	2			
4	FLANGE BOLT (S-TITE)		FTQ0410M0	7			
5	CONDENSER - WATER COOLING		2X0688G01	1			
6	CLAMP(B) - CONDENSER		4H0622-01	3			
7	TRUSS HEAD TAPPING SCREW T2		FT20408F0	3			
8	EVAPORATOR	(IM-45WNE)	3H5611G02	1			
		(IM-45WNE-25)	3H3941G01	1			
9	FITTING(P)		3Y0747-01	2			
10	NUT (A) - FITTING		415713-03	2			
11	TAPPERED PACKING		415715-01	2			
12	BRACKET - WATER REGURATOR		4X5632-01	1			
13	WATER REGULATOR		448082-01	1			
14	TRUSS HEAD MACHINE SCREW		FST0406S0	2			
15	BRACKET - HOT GAS VALVE		4H5186-01	1			
16	HOT GAS VALVE		P02539-01	1			
17	STRAINER		P00008-01	1			
18	PIPE(C) - WATER		4Y7391M01	1			
19	FLARE NUT	3*8	456441F01	1			
20	PIPE(A) - WATER		4Y7392G01	1			
21	PIPE(B) - WATER		4Y7393M01	1			
22	FLARE NUT	3*8	456441F01	1			
23	PIPE(A) - HIGH SIDE		4Y7394M01	1			
24	TEE		417394-01	1			
25	PIPE(B) - HIGH SIDE		4Y7395M01	1			
26	TEE		420041-03	2			
27	PRESSURE SWITCH	R134a,R22,R404A	459863-01	1			
28	PIPE(A) - HOT GAS		4Y7396M01	1			
29	SLEEVE		441322-01	1			
30	PIPE(C) - HIGH SIDE		4Y7397M01	1			
31	DRIER		445655-03	1			
32	PUSH MOUNT TIE		436156-01	1			
33	PIPE(D) - HIGH SIDE		4Y7398M01	1			
34	PIPE(A) - LOW SIDE		3Y5934G01	1			

HE

MODEL: <b>IM-45WNE,IM-45WNE-25</b>		TITLE: <b>B.REFRIGERATION ASSY</b>					
INDEX NO.	DESCRIPTION	MATERIAL OR MODEL NUMBER	PART NUMBER	REQ'D NUMBER			
				A-1 B-0			
35	PIPE(B) - HOTGAS		3Y5935G01	1			
36	HEAT EXCHANGER		2X0689G01	1			
37	TEE		420335-01	1			
38	EXPANSION VALVE		P00381-01	1			
39	VALVE COVER(B)		4Y3333-01	1			
40	VALVE COVER(A)		4Y3332-01	1			
41	PIPE(C) - HOT GAS		3Y5936G01	1			
42	PROSESS PIPE		4Y7164M01	1			
43	INSULATION		4X8643-01	1			
44	TIE	CV-150	7920-0003	2			
45	WIRE		1H4914Z01	2			
46	INSULATION - CAP		4H9594-01	1			
47	NYLON TIE	CV-100	7920-0002	2			
48	PIN		P02605-01	4			
49	WASHER		P02606-01	4			
50	CLAMP		P02607-01	4			
51	RUBBER GROMMET		P02608-01	4			
52	TERMINAL COVER		P02609-01	1			
53	SCREW		P00840-01	2			
54	BRACKET FOR CAPACITOR		P02610-01	1			
55	START CAPACITOR	(50Hz)	P02620-01	1			
		(60Hz)	P02611-01	1			
56	TERMINAL BOARD		P02612-01	1			
57	STARTING RELAY	(50Hz)	P02613-01	1			
		(60Hz)	P02619-01	1			
58	MOTER PROTECTOR	(50Hz)	P02618-01	1			
		(60Hz)	P02614-01	1			
59	PROTECTOR RETAINER		P00839-01	1			
60	SELF TAPPING SCREW M4-11		P02615-01	1			
61	SELF TAPPING SCR W M4-21		P02616-01	1			

IM-45NE  
 IM-45NE-25  
 IM-45WNE  
 IM-45WNE-25 C. ICE MAKING MACHANISM ASSY (A-1) and later

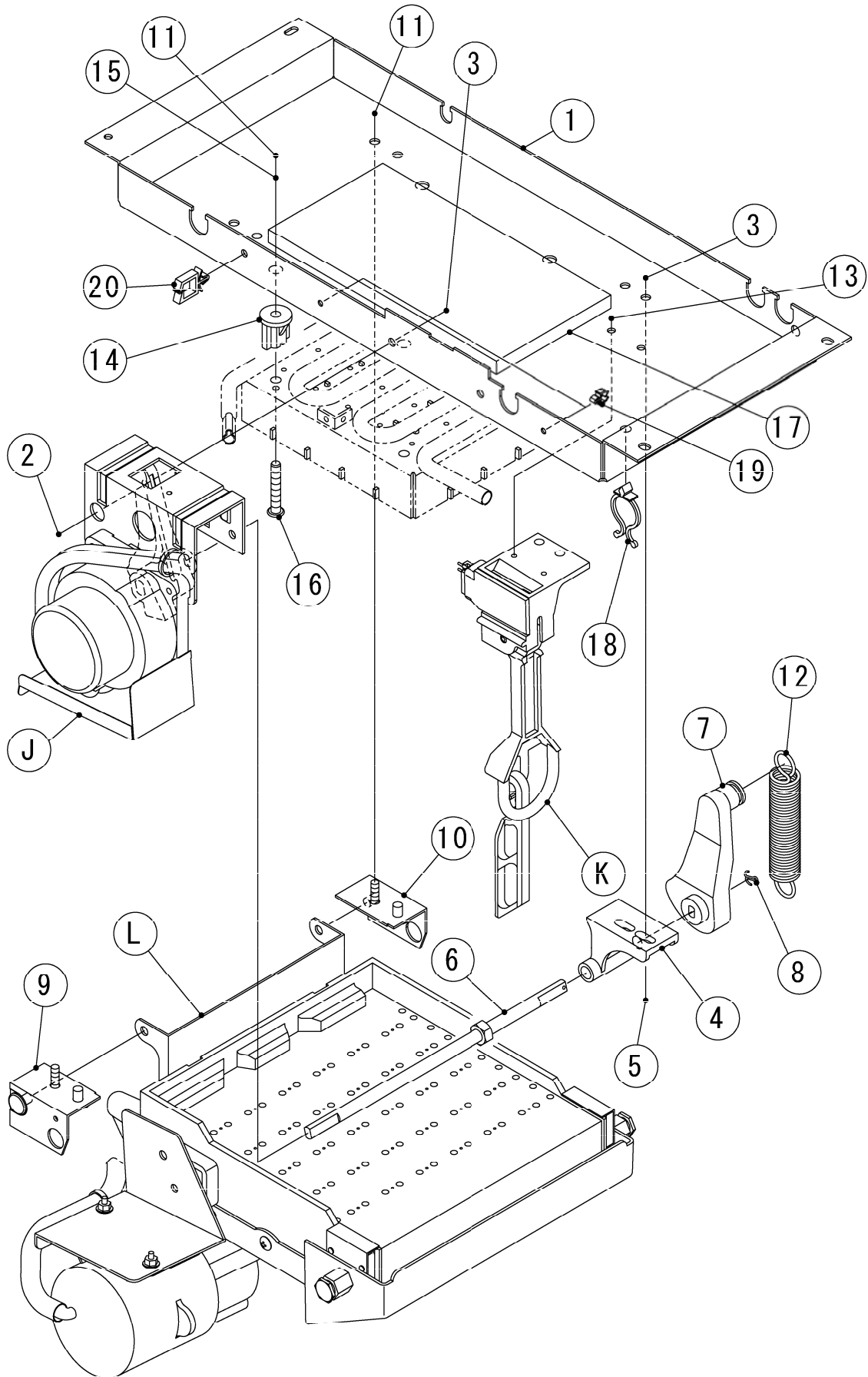

HE,GRAM

MODEL: <b>IM-45NE,IM-45NE-25 IM-45WNE,IM-45WNE-25</b>		TITLE: <b>C.ICE MAKING MECHANISM ASSY</b>					
INDEX NO.	DESCRIPTION	MATERIAL OR MODEL NUMBER	PART NUMBER	REQ'D NUMBER			
				A-1 B-0			
J	ACTUATOR MOTOR ASSY		3Y5641A01	1			
K	BIN CONTROL SWITCH		3H1537A02	1			
L	WATER PAN ASSY		2X0437A01	1			
1	MECHANISM BASE	(IM-45NE,IM-45WNE)	2X0434M01	1			
		(IM-45NE-25,IM-45WNE-25)	2X0723M01	1			
2	TRUSS HEAD MACHINE SCREW		FST0512S0	2			
3	FLANGE NUT		FNHF05S0	4			
4	CAM SHAFT BEARING		307256-01	1			
5	TRUSS HEAD MACHINE SCREW		FST0516S0	2			
6	CAM SHAFT		4H2589G01	1			
7	CAM (B)		3H1389-01	1			
8	COTTER PIN		711S-0212	1			
9	BEARING (FRONT) - WATER PAN		4H2591G02	1			
10	BEARING (REAR) - WATER PAN		4H2592G02	1			
11	FLANGE NUT		FNHF06S0	6			
12	SPRING		4H2640-01	1			
13	TRUSS HEAD TAPPING SCREW T2		FT20410M0	2			
14	SPACER	(IM-45NE,IM-45WNE)	4H0471-01	4			
		(IM-45NE-25,IM-45WNE-25)	4X5342-01	4			
15	WASHER		4H0777-01	4			
16	SCREW EVAPORATOR		4Y4922M01	4			
17	INSULATION (D)		4Y7347P01	1			
18	CLAMP	No.2674	427902-02	1			
19	CLAMP		426197-01	2			
20	WIRE SADDLE		428060-03	1			

IM-45NE  
IM-45NE-25  
IM-45WNE  
IM-45WNE-25  
IM-45CNE  
IM-45CNE-25

D. WATER CIRCUIT ASSY

(A-1) and later

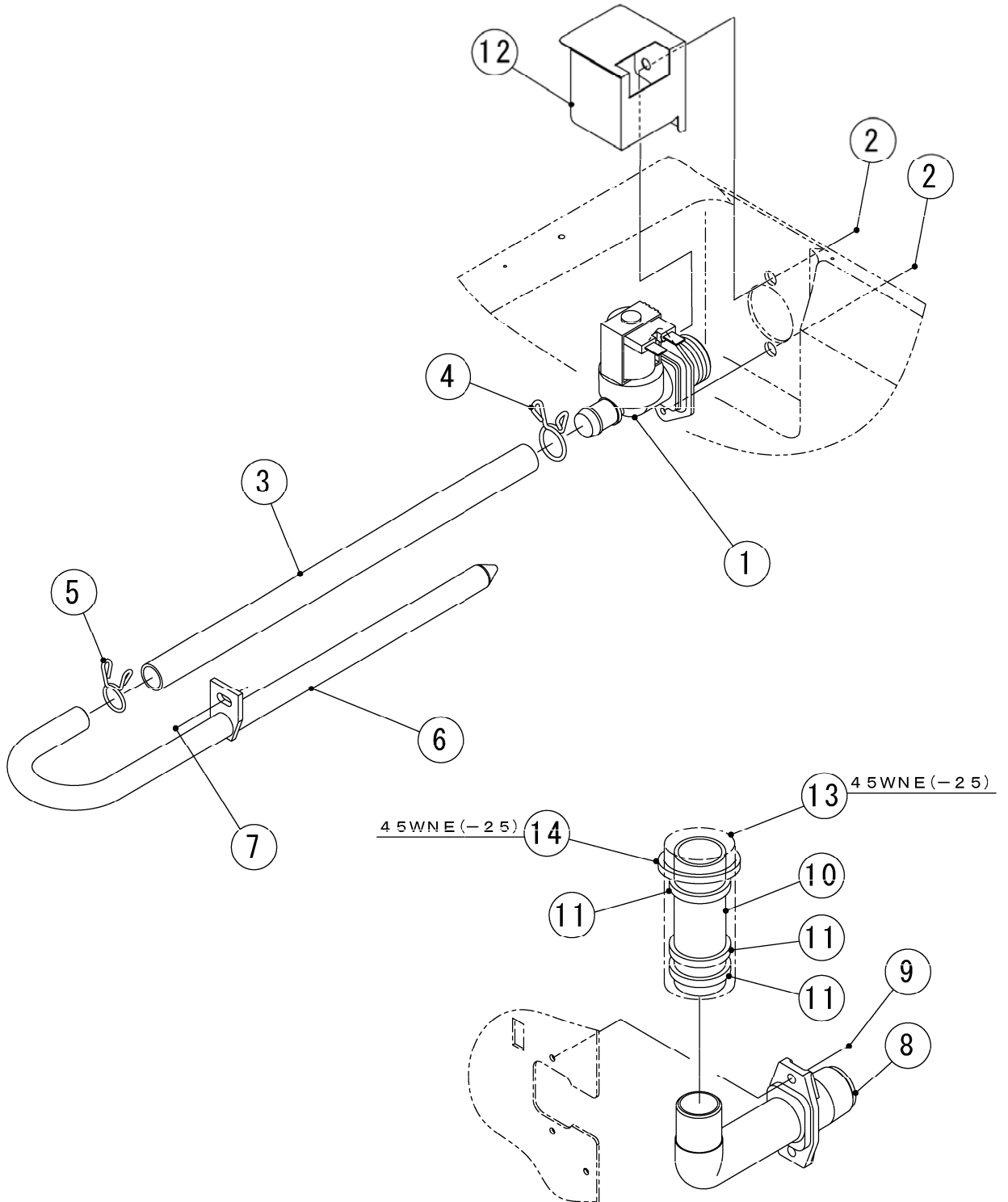





IM-45NE  
IM-45NE-25  
IM-45WNE  
IM-45WNE-25  
IM-45CNE  
IM-45CNE-25

E. CONTROL BOX ASSY

(A-1) and later

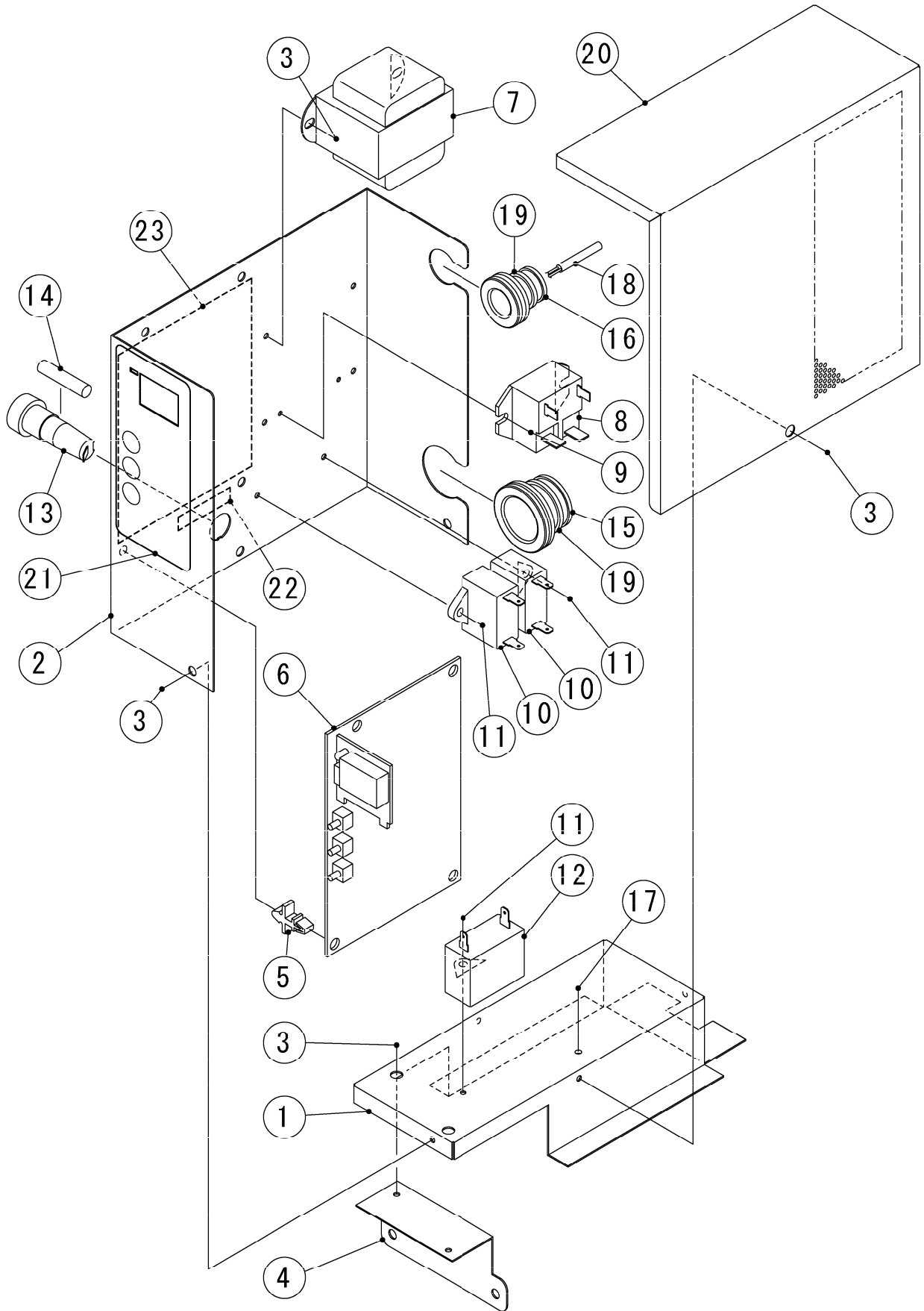

HE,GRAM

MODEL: **IM-45NE,IM-45NE-25**  
**IM-45WNE,IM-45WNE-25**

TITLE:**E.CONTROL BOX ASSY**

(1/1)

INDEX NO.	DESCRIPTION	MATERIAL OR MODEL NUMBER	PART NUMBER	REQ'D NUMBER			
				A-1 B-0			
1	CONTROL BOX (A)		3Y5611M01	1			
2	CONTROL BOX(B)		2X0438M01	1			
3	TRUSS HEAD TAPPING SCREW T2		FT20408F0	8			
4	PLATE - BOX		4Y7215M01	1			
5	BOARD SUPPORT		414929-02	4			
6	CONTROLLER BOARD		P01873-01	1			
7	TRANSFORMER		P00012-01	1			
8	POWER RELAY		P02203-02	1			
9	TRUSS HEAD TAPPING SCREW T2		FT20308F0	2			
10	CAPACITOR		P01870-01	2			
11	TRUSS HEAD TAPPING SCREW T2		FT20410F0	3			
12	CONDENSER		P02158-01	1			
13	FUSE HOLDER		P00014-01	1			
14	FUSE		P01876-01	1			
15	GROMMET		4H2568-01	1			
16	GROMMET		4H2568-02	1			
17	TRUSS HEAD MACHINE SCREW		FST0408S0	1			
18	THERMISTOR - CUBE COTROL		P00350-01	1			
19	TIE	CV-150	7920-0003	2			
20	CONTROL BOX COVER		3Y5612M01	1			
21	CONTROL LABEL		475642L01	1			
22	LABEL - FUSE		466798-01	1			
23	WIRING LABEL		3Y5648L01	1			

IM-45NE  
IM-45NE-25  
IM-45WNE  
IM-45WNE-25

F. DOOR ASSY

(A-1) and later

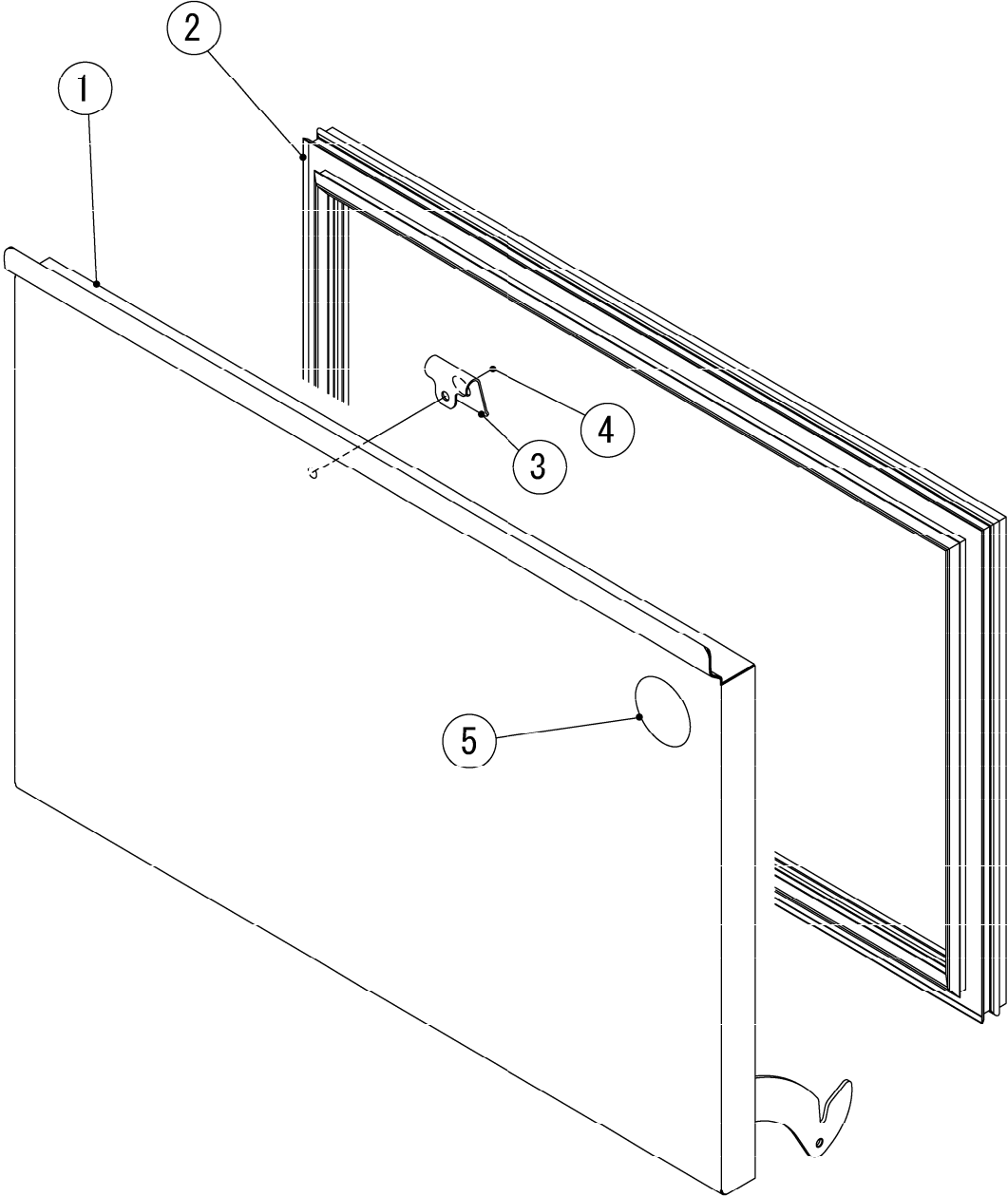

HE,GRAM

MODEL: <b>IM-45NE,IM-45NE-25</b> <b>IM-45WNE,IM-45WNE-25</b>					TITLE: <b>F.DOOR ASSY</b>			
INDEX NO.	DESCRIPTION	MATERIAL OR MODEL NUMBER	PART NUMBER	REQ'D NUMBER				
				A-1 B-0				
1	DOOR - INSULATION	(HE) Including No. 5	3Y5613G01	1				
		(GRAM)	3Y5613001	1				
2	DOOR GASKET		3X6199P02	1				
3	CATCH - SLOPE		4X7644-01	1				
4	TRUSS HEAD TAPPING SCREW T2		FT20408M0	1				
5	LABEL - PENGUIN	(HE)	471486L01	1				

(1/1)

IM-45NE  
IM-45NE-25 G. FRONT PANEL LOWER ASSY (A-1) and later

---

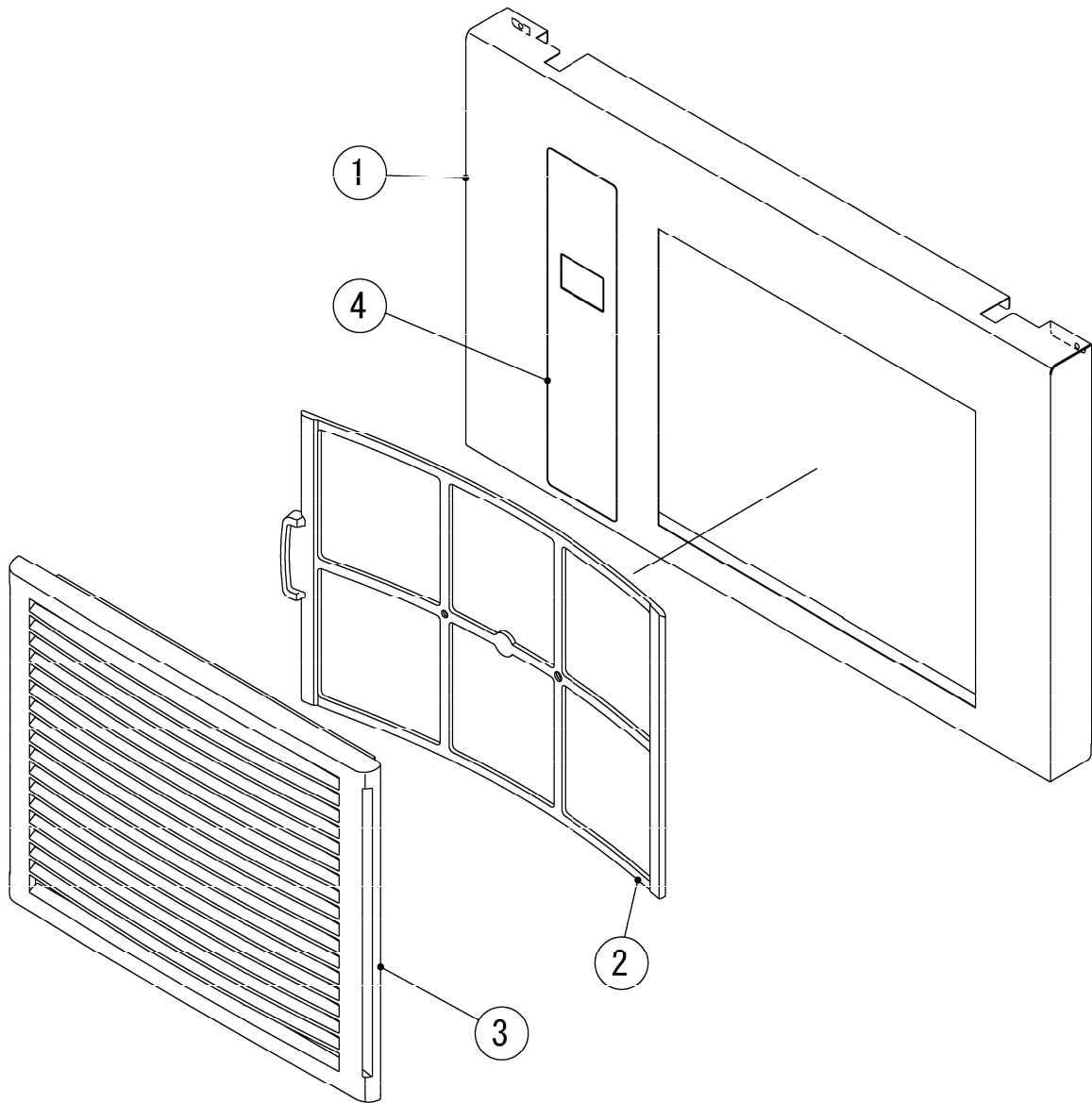



IM-45NE  
IM-45NE-25  
IM-45CNE  
IM-45CNE-25

H. FAN MOTOR ASSY

(A-1) and later

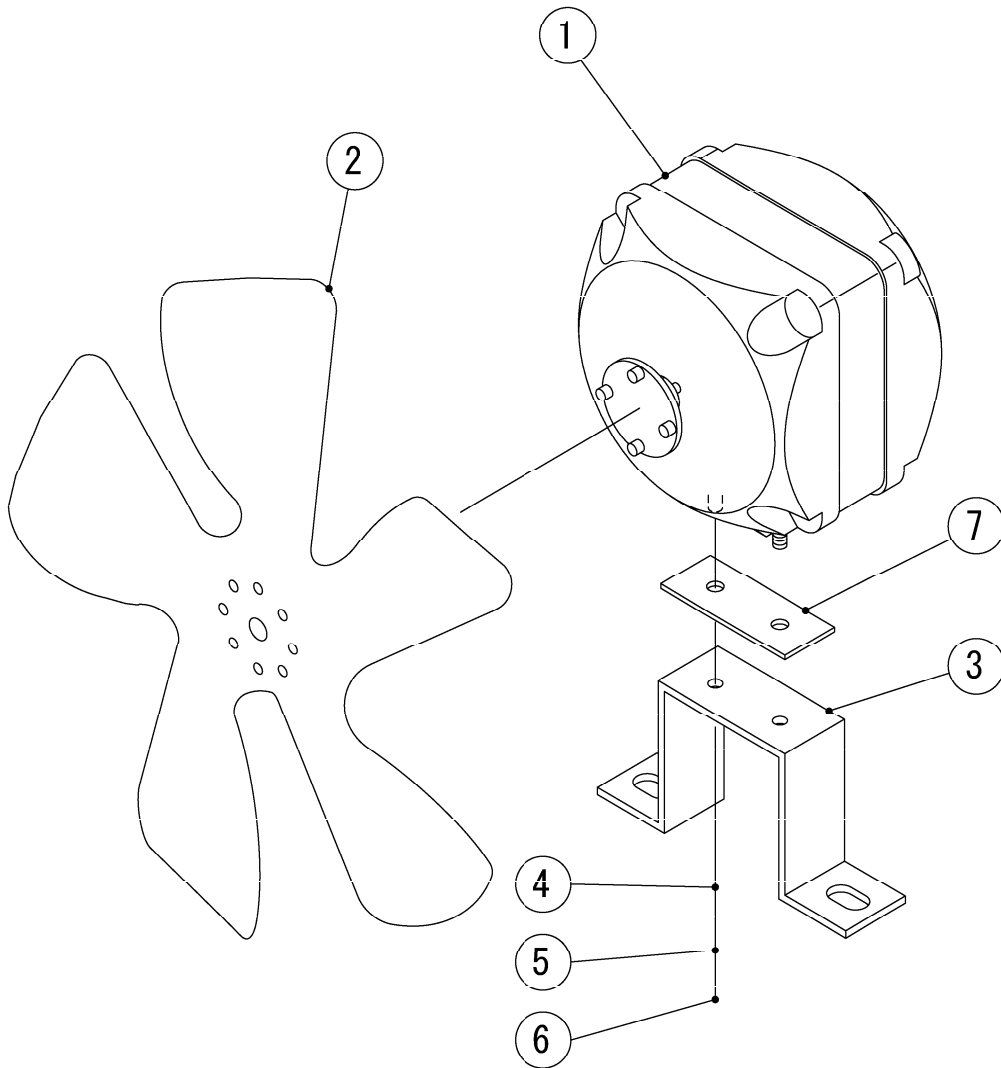





IM-45NE  
IM-45NE-25  
IM-45WNE  
IM-45WNE-25  
IM-45CNE  
IM-45CNE-25

J. ACTUATOR MOTOR ASSY

(A-1) and later

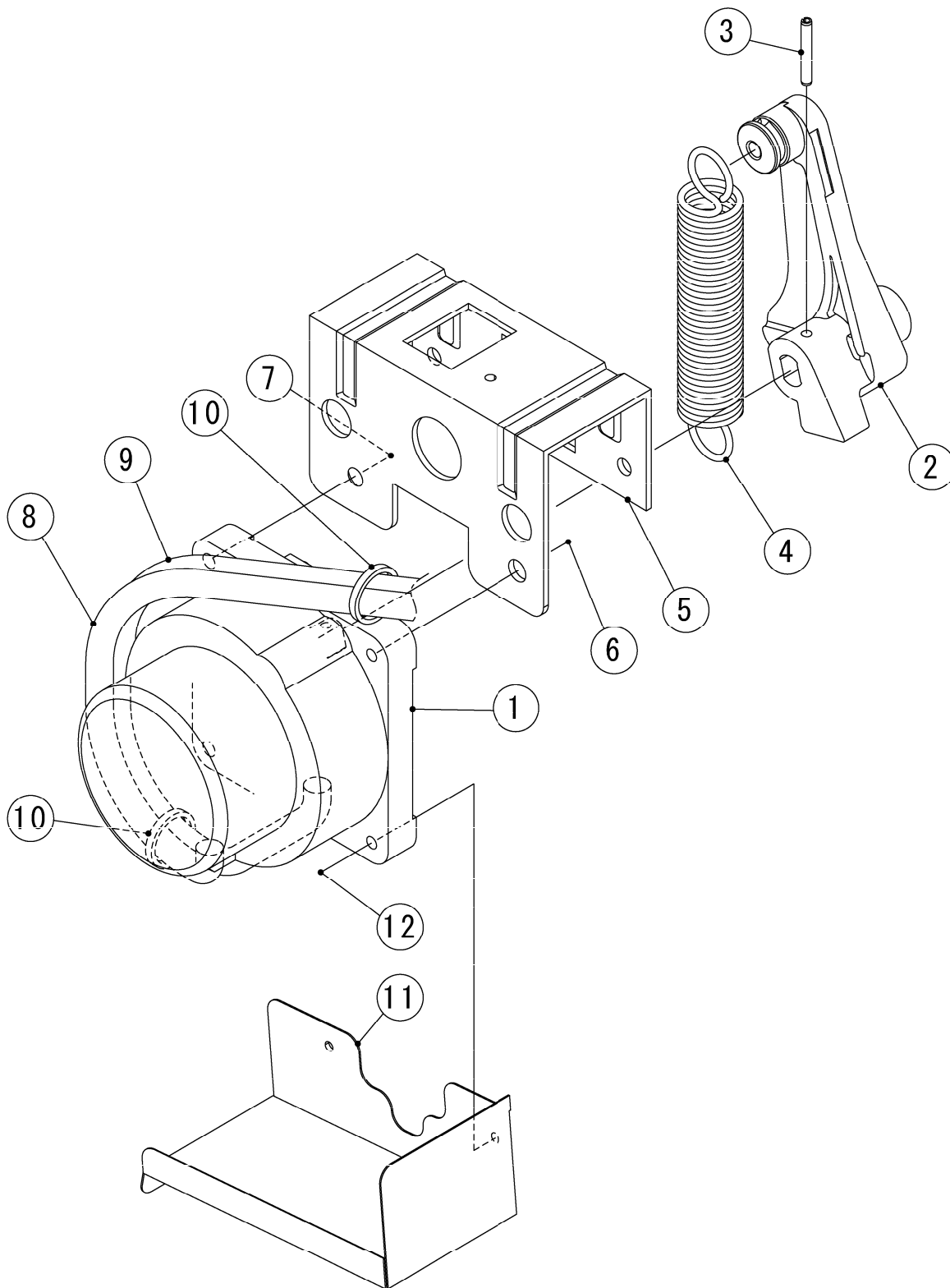

HE,GRAM

		MODEL: <b>IM-45NE,IM-45NE-25 IM-45WNE,IM-45WNE-25</b>		TITLE: <b>J.ACTUATOR MOTOR ASSY</b> <span style="float: right;">(1/1)</span>			
INDEX NO.	DESCRIPTION	MATERIAL OR MODEL NUMBER	PART NUMBER	REQ'D NUMBER			
				A-1 B-0			
1	ACTUATOR MOTOR		P01869-01	1			
2	CAM (A)		3Y2277P01	1			
3	SPRING PIN		712S-0322	1			
4	SPRING		4H2640-01	1			
5	BRACKET - ACTUATOR MOTOR		3H1388-04	1			
6	TRUSS HEAD MACHINE SCREW		FST0612S0	1			
7	FLAT HEAD MACHINE SCREW		FSF0612S0	1			
8	TUBE - SILICONE		4Y6751Z01	1			
9	TUBE - SILICONE		4X8017-01	1			
10	TIE	CV-150	7920-0003	2			
11	COVER - AM		3Y5292M01	1			
12	HEX HEAD BOLT (SPRING WASHER AND FLAT WASHER)		FBK0416S0	2			

IM-45NE  
IM-45NE-25  
IM-45WNE  
IM-45WNE-25

K. BIN CONTROL SWITCH

(A-1) and later

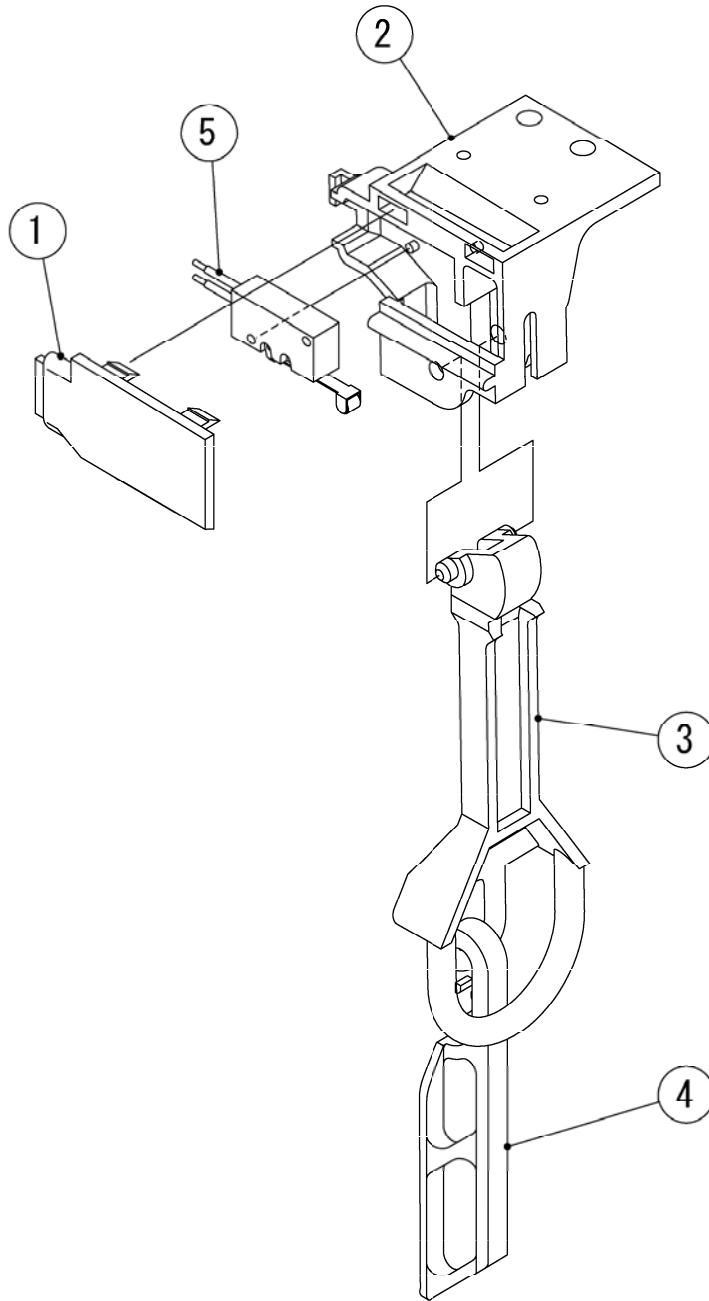

HE,GRAM

MODEL: <b>IM-45NE,IM-45NE-25</b> <b>IM-45WNE,IM-45WNE-25</b>			TITLE: <b>K.BIN CONTROL SWITCH</b>				
INDEX NO.	DESCRIPTION	MATERIAL OR MODEL NUMBER	PART NUMBER	REQ'D NUMBER			
				A-1 B-0			
1	SWITCH BOX COVER		4H8785-01	1			
2	SWICH BOX		2H2043-01	1			
3	SWITCH ACTUATOR		3H1369-01	1			
4	DETECTOR		3H0633-01	1			
5	MICRO SWITCH		456432-02	1			

(1/1)

IM-45NE  
IM-45NE-25  
IM-45WNE  
IM-45WNE-25  
IM-45CNE  
IM-45CNE-25

L. WATER PAN ASSY

(A-1) and later

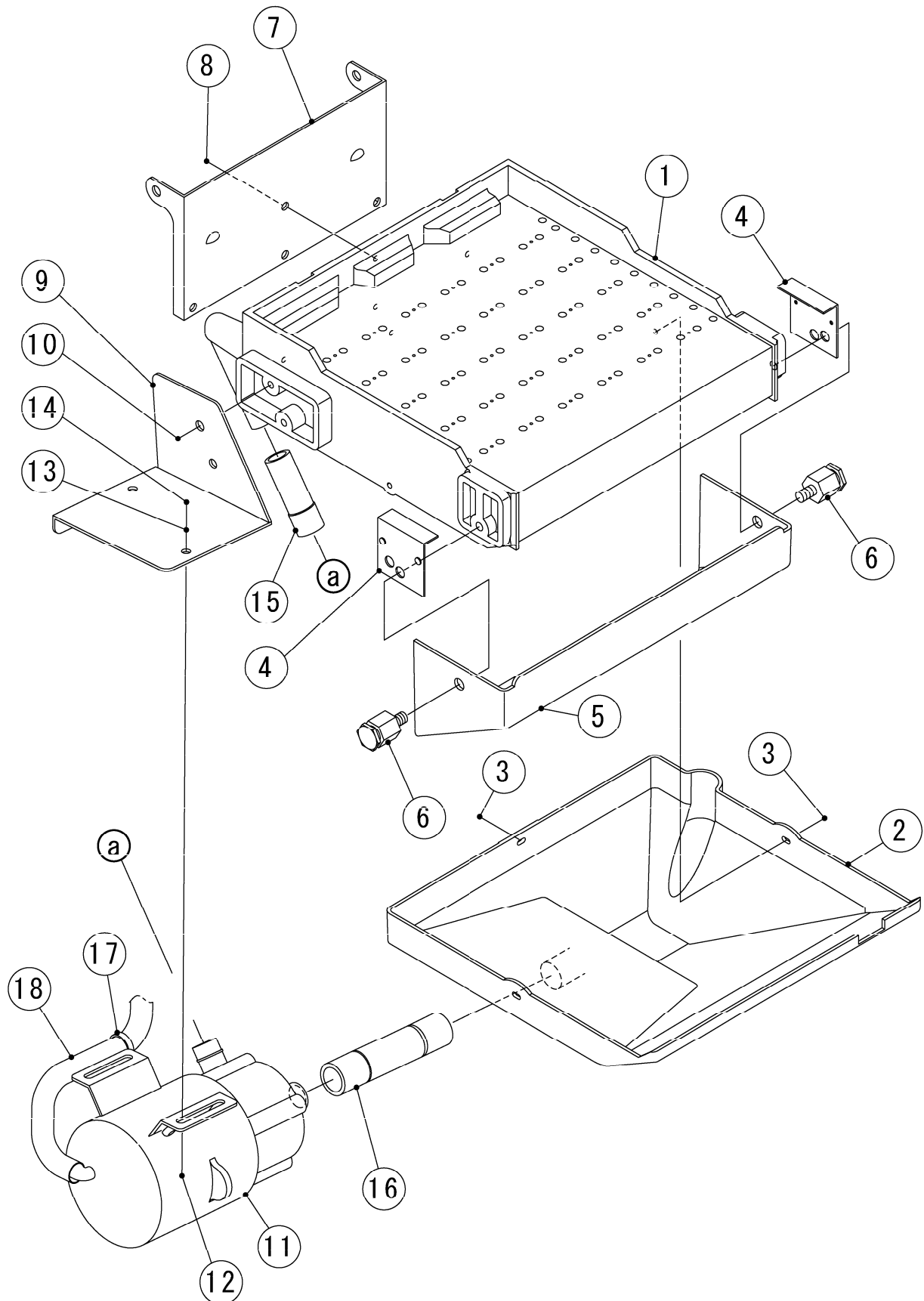

HE,GRAM

MODEL: <b>IM-45NE,IM-45NE-25</b> <b>IM-45WNE,IM-45WNE-25</b>		TITLE: <b>L.WATER PAN ASSY</b>					
INDEX NO.	DESCRIPTION	MATERIAL OR MODEL NUMBER	PART NUMBER	REQ'D NUMBER			
				A-1 B-0			
1	WATER PLATE	(IM-45NE,IM-45WNE)	2H0402G02	1			
		(IM-45NE-25,IM-45WNE-25)	2H0402G03	1			
2	WATER TANK(AD)		4X4159-02	1			
3	TRUSS HEAD TAPPING SCREW T2		FT20408M0	3			
4	PLATE - LUBRICATION		4H0448-01	2			
5	DRAIN GUIDE		3H5521-01	1			
6	SCREW SPRING HOOK		4H2582G01	2			
7	BRACKET - WATER PAN		4H2643-02	1			
8	TRUSS HEAD TAPPING SCREW T2		FT20412M0	4			
9	BRACKET - PUMP MOTOR		4Y7294M01	1			
10	TRUSS HEAD TAPPING SCREW T2		FT20512M0	2			
11	PUMP MOTOR		P02132-01	1			
12	HEX HEAD BOLT		FBH0412S0	2			
13	FLAT WASHER		FWPL04S0	2			
14	FLANGE NUT		FNHF04S0	2			
15	DISCHARGE TUBING		4H1982-01	1			
16	SUCTION TUBING		4H1922-02	1			
17	NYLON TIE	CV-150	7920-0003	1			
18	TUBE - SILICONE		4Y6751Z03	1			

IM-45NE  
IM-45NE-25  
IM-45WNE  
IM-45WNE-25  
IM-45CNE  
IM-45CNE-25

M. ACCESSORIES

(A-1) and later

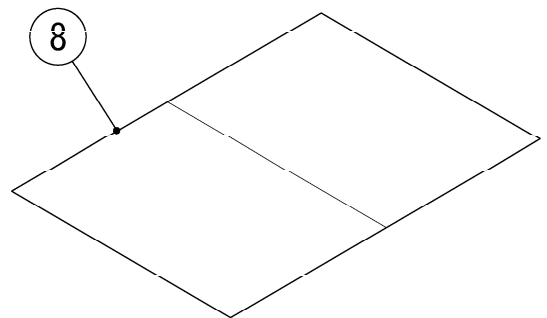
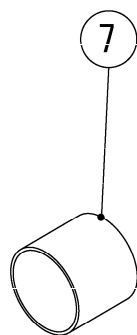
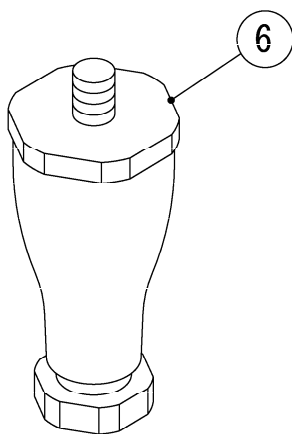
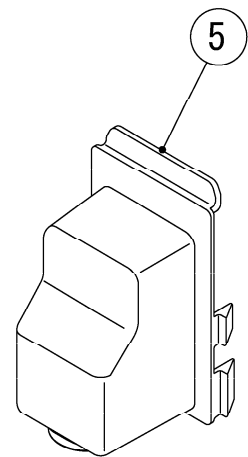
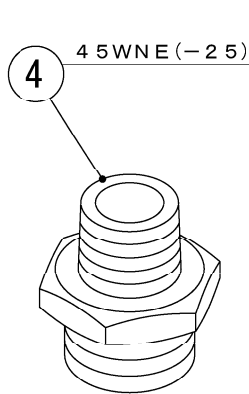
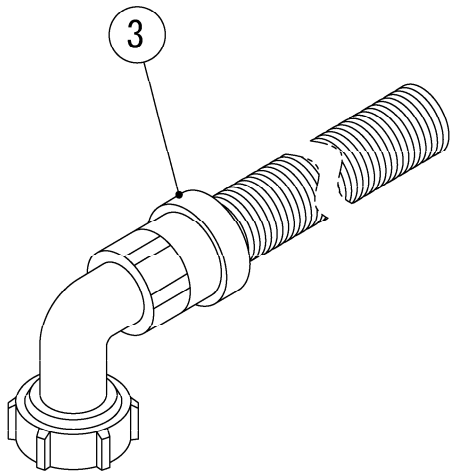
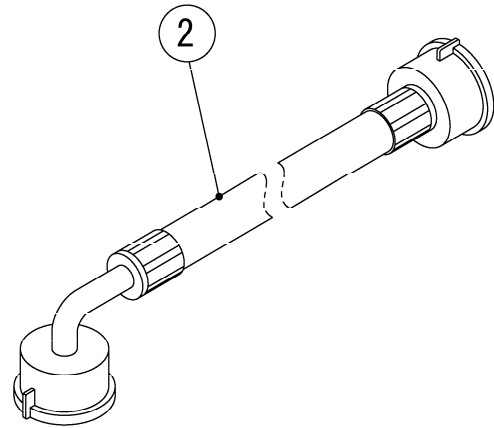
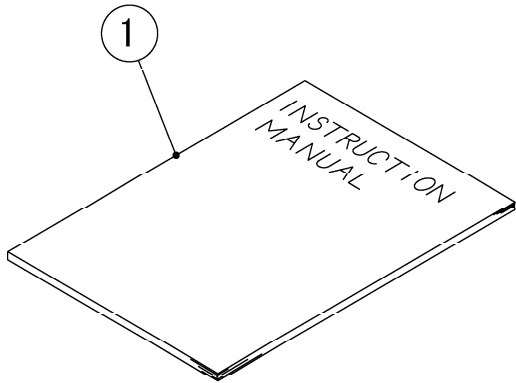

HE,GRAM

MODEL: <b>IM-45NE,IM-45NE-25</b> <b>IM-45WNE,IM-45WNE-25</b>					TITLE: <b>M.ACCESSORIES</b>			
INDEX NO.	DESCRIPTION	MATERIAL OR MODEL NUMBER	PART NUMBER	REQ'D NUMBER				
				A-1 B-0				
1	INSTRUCTION MANUAL		L1E1EC201	1				
2	INLET HOSE	(IM-45NE,-25)	450722-01	1				
		(IM-45WNE,-25)		2				
3	OUTLET HOSE	(IM-45NE,-25)	452365-01	1				
		(IM-45WNE,-25)		2				
4	ADAPTOR	(IM-45WNE,-25)	450724-01	2				
5	COVER - CONNECTOR		2X0271P01	1				
6	LEG		462576-02	4				
7	CAP		417323-01	1				
8	INSTRUCTION SHEET		121594L01	1				